

**Ph.D. Preliminary Examination Solution
Spring 2009**

Instructions:

1. Please check to ensure that you have a complete exam booklet. There are 25 numbered problems. Note that **problem 1 and 14 has 2 pages**. Including the cover sheet, you should have **28 pages**. There should be no blank pages in the booklet.
2. The examination is closed book and closed notes. No reference material is allowed at your desk. A calculator is permitted.
3. All wireless devices must be turned off for the entire duration of the exam.
4. You may work a problem directly on the problem statement (if there is room) or on blank sheets of paper available from the exam proctor. Do not write on the back side of any sheet.
5. Your examination code number **MUST APPEAR ON EVERY SHEET**. This includes this cover sheet, the problem statement sheets, and any additional work sheets you turn in. **DO NOT** write your name on any of these sheets. Use the preprinted numbers whenever possible, or **WRITE LEGIBLY!!!**
6. Under the rules of the examination, you must choose 8 problems to be handed in for grading. Each problem to be graded should be separated from the rest of the materials, stapled to the associated worksheets, and placed on the top of the appropriate envelope in the front of the exam room. **DO NOT TURN IN ANY SHEETS FOR THE OTHER 17 PROBLEMS!!**
7. The examination lasts 4 hours, from 9:30 AM to 1:30 PM.
8. When you hand in the exam:
 - (a) Separate the 8 problems to be graded as explained above.
 - (b) Check to see that your Code Number is in **EVERY** sheet you are turning in.
 - (c) On the section at the bottom of this page, **CIRCLE** the problem numbers that you are turning in for grading.
 - (d) Turn in this cover sheet (containing your code number) and the 8 problems to be graded.
 - (e) All other material is to be placed in the discard box at the front of the room. You are not allowed to take any of the exam booklet pages from the room!

1	2	3	4	5	6	7	8	9
10	11	12	13	14	15	16	17	18
19	20	21	22	23	24	25		

Problem 1 (Core: CompE-ECE2030)

Code Number: _____

Write the logic function implemented by this circuit in the space provided.

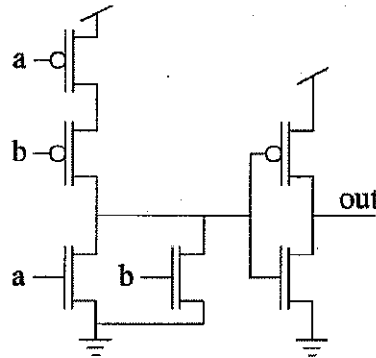

$$\overline{a \cdot b} = a + b$$

a + b

Fill-in the K-map below for the given function.

$$F = \overline{(\overline{B} \overline{C} + BC)} + \overline{A}BD = B\overline{C} + \overline{B}C + \overline{A}BD$$

$F_0 :$

		\overline{C}		C		
		CD				
\overline{A} } A }	AB	00	01	11	10	\overline{B} } B } \overline{B} }
	00	0	0	1	1	
	01	1	1	1	0	
	11	1	1	0	0	
	10	0	0	1	1	
		\overline{D}		D	\overline{D}	

Problem 1 (cont.) (Core: CompE-ECE2030) Code Number: _____

Write down a simplified function from the Karnaugh map in the space provided in the sum-of-products form and in the product-of-sums form ("Don't cares" are marked by x 's). Note, the two tables are identical so that you may use one to derive the SOP form and one to derive the POS form if desired. Show your work for full credit.

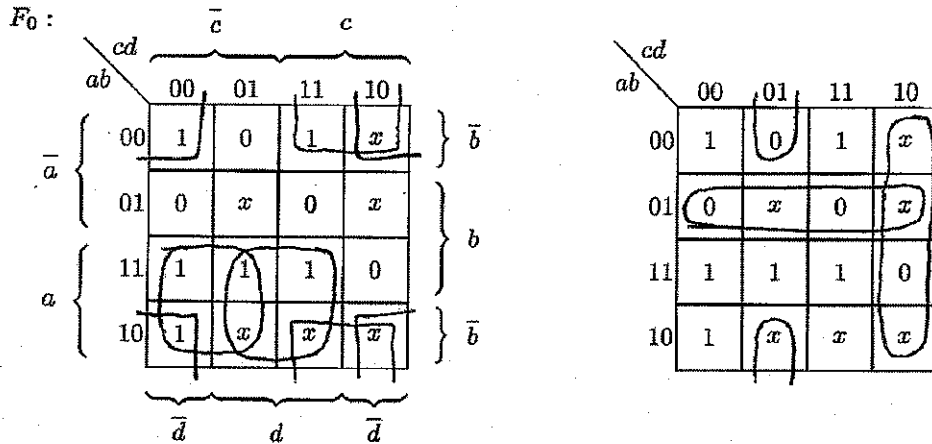

SOP: $a\bar{c} + ad + \bar{b}c + \bar{b}\bar{d}$
POS: $(a + \bar{b})(\bar{c} + d)(b + c + \bar{d})$

Problem 2 (Core: CompE-ECE2030)

Code Number: _____

Design a synchronous 3-bit binary counter that counts in the sequence 0,7,2,3,5 and repeats. Denote the three bits as "A,B,C" where "A" is the most-significant-bit (i.e. count 3 is encoded as ABC=011). Assume that 3 D type flip flops will be used for the state register, and that each flip flop provides both uncomplemented and complemented outputs.

(a) Draw a state diagram for the counter.

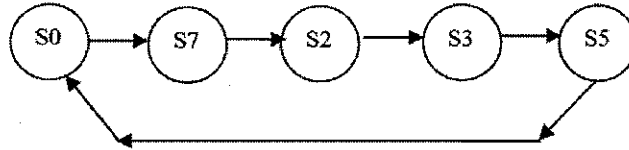

(b) Determine the minimized Sum-of-Products (SOP) Boolean expressions for the input logic functions. Be sure to take advantage of "unused" states in order to help minimize the logic complexity.

Present State ABC	Next State / Inputs for D-FFs A ⁺ B ⁺ C ⁺
000 (S0)	111 (S7)
001	XXX
010 (S2)	011 (S3)
011 (S3)	101 (S5)
100	XXX
101 (S5)	000 (S0)
110	XXX
111 (S7)	010 (S2)

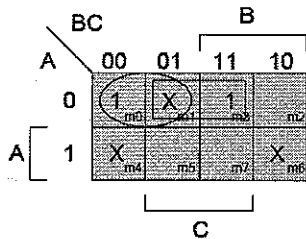

$$D_A = A^+ = A'B' + A'C$$

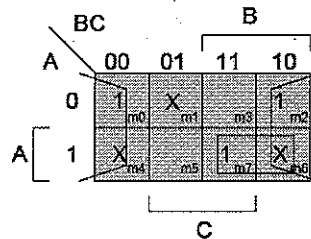

$$D_B = B^+ = C' + AB$$

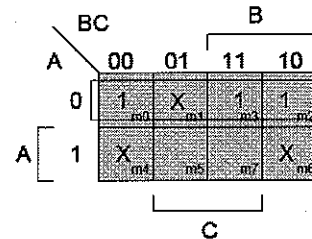

$$D_C = C^+ = A'$$

(c) If the counter starts in state ABC=000, determine its state after 113 clock cycles.

Notice that after each 5 clocks, the counter returns to the original state (ABC=000).

$$113 \text{ cycles} = 22 \times 5 + 3$$

Therefore, from the state diagram (Part a) we can see that the counter will end in state S3, ABC=011.

(d) Assume that each of the logic gates and flip flops have propagation delays of $T_{pd}=1.4\text{ns}$ and that the flip flop has set-up time $T_{su}=0.8\text{ns}$ and hold time $T_h=0.2\text{ns}$. Predict the maximum expected frequency (F_{max}) for the counter.

The longest (critical) path (or "feedback") signal is from the outputs of the flip-flops (one T_{pd} after the clock edge), through one set of AND gates (a second T_{pd}), followed by an OR gate (3^{rd} T_{pd}), back to the D inputs of the flip flops, so the propagation delay is $3 \times 1.4\text{ns} = 4.2\text{ns}$. However, the feedback signal must arrive at that input early enough to satisfy the "set-up time". Therefore the minimum clock period $T_{clk_{MN}} = 3 \times 1.4\text{ns} + 0.8\text{ns} = 5\text{ns}$, corresponding to a maximum frequency of **200 MHz**. The hold-time requirement will be satisfied since the clock period is much longer than 0.2ns.

Problem 3 (Core: CompE-ECE3055)**Code Number:** _____

The following RISC assembly language program is executed on a 32-bit MIPS processor. Fill in the register values that will be present, after execution of this program. A summary of MIPS instructions is included at the bottom of the page – for anyone unfamiliar with the MIPS instruction set. Prior to execution of the program, memory location 0x02000 contains 0x20313055. *Note:* 0x indicates hexadecimal and all answers must be in hexadecimal, default is decimal in the MIPS assembly language source file. A MIPS memory word or register contains 32-bits. Use XXXXXXXX for an undefined value.

```

lw          $3, 0x02000
sll        $4, $3, 10
sub        $2, $4, $3
xor        $3, $4, $2
lui        $5, 0
ori        $5, $5, 12373
add        $6, $4, $3
bne        $3, $6, LABEL1
addi       $6, $0, -20
LABEL1:    sw          $6, 0x02000

```

After execution of the MIPS code sequence above,

R2 = 0x__A49023AB_____ (in hexadecimal)

R3 = 0x__605177AB_____ (in hexadecimal)

R4 = 0x__C4C15400_____ (in hexadecimal)

R5 = 0x__00003055_____ (in hexadecimal)

Memory Location 0x02000 contains: 0x__2512CBAB_____ (in hexadecimal)

The MIPS processor contains thirty-two 32-bit registers, \$0 through \$31. \$0 always contains a zero. By default, all arithmetic operations use two's complement arithmetic. Assume no branch delay slot is present.

<u>MIPS Instruction</u>	<u>Meaning</u>
ADDI Rd, Rs, <i>Immed</i>	- Rd = Rs + <i>Immediate</i> value
ADD Rd, Rs, Rt	- Rd = Rs + Rt (R – register (\$))
ORI Rd, Rs, <i>Immed</i>	- Rd = Rs low 16-bits bitwise logical OR <i>Immediate</i> value
LUI Rd, <i>Immed</i>	- Rd = 16-bit <i>Immediate</i> value high 16-bits, 0's low 16-bits
BNE Rs, Rt, <i>address</i>	- Branch to <i>address</i> , only if Rs not equal to Rt
LW Rd, <i>address</i>	- LOAD - Rd gets contents of memory at <i>address</i>
SLL Rd, Rs, <i>count</i>	- Shift left logical (<i>use 0 fill</i>) by <i>count</i> bits
SUB Rd, Rs, Rt	- Rd = Rs - Rt
SW Rd, <i>address</i>	- STORE - memory at <i>address</i> gets contents of Rd
XOR Rd, Rs, Rt	- Rd = Rs bitwise logical XOR Rt

Problem 4 (Core: CompE-ECE3060)

Code Number: _____

In this question, the symbol C_{inv} refers to the input capacitance of minimum-sized inverter with equal rise/fall time.

A. (3pts) Compute the worst-case RC delay if a NOR6 (= 6-input NOR gate) is driving a load of $100C_{inv}$. Assume that the capacitance of each input of the NOR6 is $2C_{inv}$ and that the NOR6 has equal rise/fall time.

a)

$W(\text{in FET}) = 2 \times 3 \times \frac{1}{13}$
 $\therefore R(\text{PD}) = \frac{R}{\frac{6}{13}} = \frac{13R}{6}$
 $\therefore \text{delay} = \frac{13R}{6} \times 100 C_{inv}$
 $= \boxed{216.7 \tau}$

B. (4pts) Consider $F = xy' + yz' + z$. Draw the stick diagram of the network-of-gate implementation of F using NOR2 and INVs only. Assume that the complemented inputs are available.

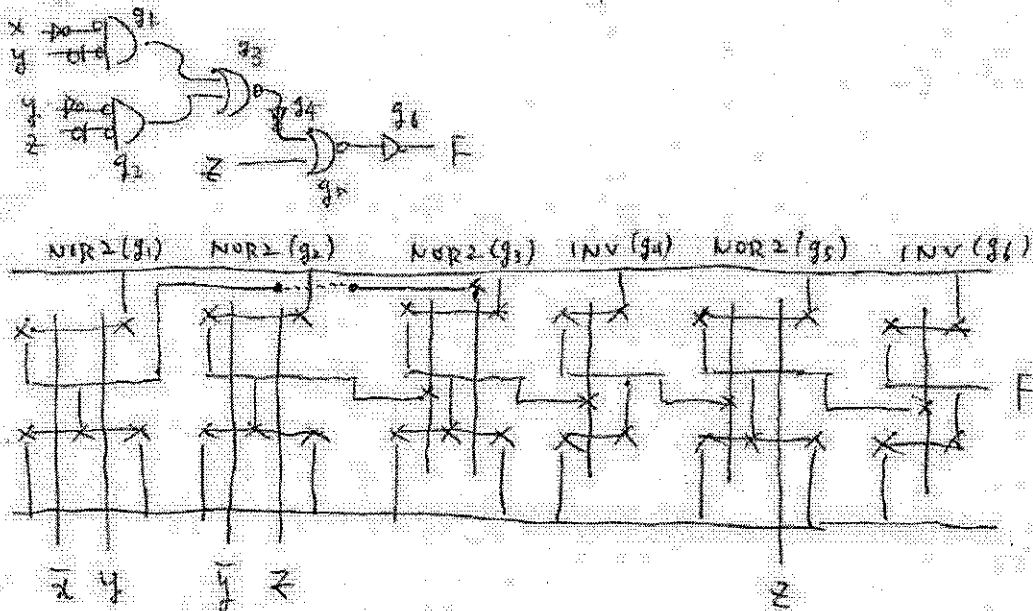

Problem 5 (Core: E&M-ECE3025)

Code Number: _____

For $t < 0$, the voltage across the TL on the left (L) is V which we can decompose into left- and right-going amplitudes V_{ss}^+ and V_{ss}^- , each of $V/2$. We can obtain this from the TL equations for $t < 0$,

$$V = V_{ss}^+ + V_{ss}^-$$

$$Z_0 I = V_{ss}^+ - V_{ss}^-$$

with I the current in TL L for $t < 0$.

At $t = 0$, the reflection coefficient for L near at the junction changes from $\Gamma_F = 1$ to $\Gamma_F = 0$ (since the two TLs are impedance matched). This means the new total left-going amplitude at the junction on L must be $V_{new}^- = \Gamma_F V_{ss}^+ = (0)(V/2) = 0$. But, $V_{new}^- = V_{ss}^- + V$ where V is the amplitude of a new left-going step-shaped wave on L. Thus, $V = -V/2$. At the transit time T , this wave reaches the open-circuit end of L and gives rise to a reflected wave V^+ of amplitude $V^+ = -V/2$, i.e., $V^+ = -V/2$. Because the two TLs are impedance matched, there is no reflection back onto L at $2T$.

Now let us consider the TL on the right (R). Just after the switch is closed, the voltage across the junction end of L is $V_{ss}^+ + V_{new}^- = V/2 + 0 = V/2$. This launches a right-going step-shaped wave on R of amplitude $W^+ = V/2$. This wave reaches the right-hand end of R at time T , upon which there is no reflection, as the load is impedance matched to R.

At time $2T$, however, the wave $V^+ = -V/2$ on L reaches the junction and is entirely transmitted onto R producing a right-going wave of amplitude $W^{++} = V^+ = -V/2$ on R. This wave reaches the load at time $3T$. There is no reflection, and thus no further waves launched. The system has reached steady state at time $3T$.

PS By $3T$, both TLs are uncharged.

Problem 6 (Core: E&M-ECE3065)

Code Number: _____

Solution: Start by plotting the normalized load impedance, $2.4 + j1.6$, on the Smith chart. The stubs are in series with this load line (though parallel with each other), so this may be worked with impedances. There are two possible points on the Smith chart where the equivalent impedance of the load line appears to be $1.0 \pm jX$:

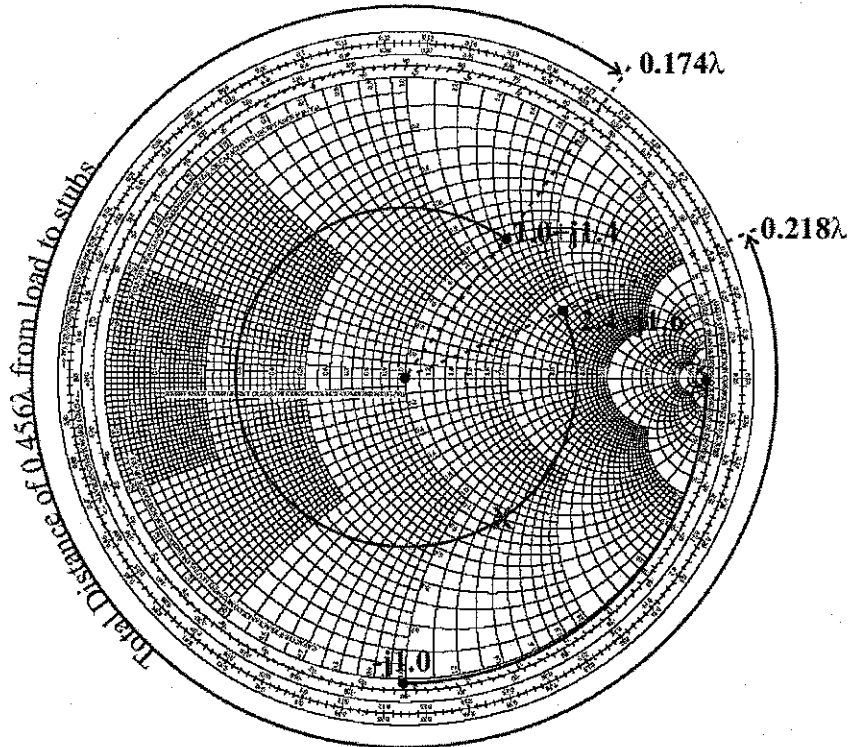

We must choose the second one because the stubs that we will use to remove the imaginary portion are *capacitive*. These short, fixed lengths cannot be inductive, regardless of the value Z_M . Therefore, the equivalent impedance of the load line 0.456λ at this juncture is $50 + j70\Omega$, unnormalized. The two $\lambda/8$ open-circuit stub lines each have an equivalent impedance of $-jZ_m$; collectively, the two stubs behave as $-j\frac{Z_m}{2}$ in the circuit:

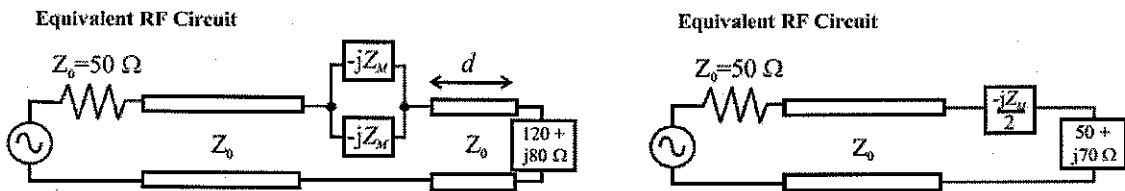

Thus, $Z_m = 140\Omega$ to remove the $+j70\Omega$ when placed in series.

Problem 7 (Core: EDA-ECE2040)

Code Number: _____

(10 pts total). **AC Circuit Analysis.** All parts of this problem refer to the circuit shown in the figure below.

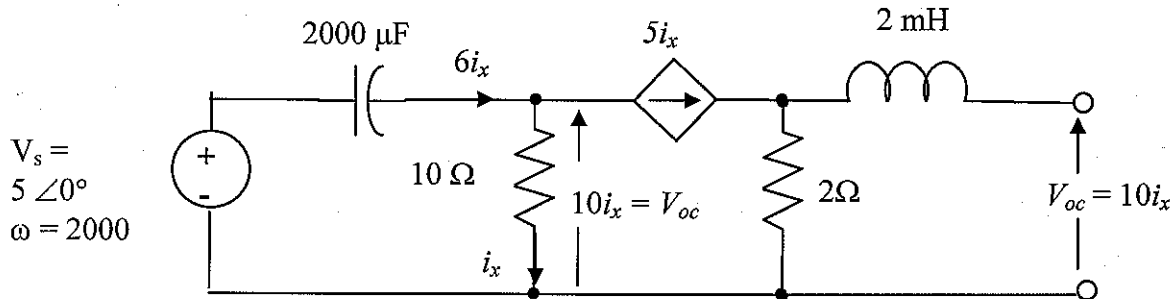

- a) (4 pts) Calculate the open circuit voltage, V_{oc} in phasor form.

From KCL : $(5 - V_{oc}) \cdot (j4) = 6i_x = 0.6V_{oc}$

$$\Rightarrow V_{oc} = j20 / (0.6 + j4) = 4.89 + j0.783 \text{ V} = \boxed{4.94 \angle 8.53^\circ \text{ volts}}$$

- b) (4 pts) Calculate the Thevenen equivalent impedance.

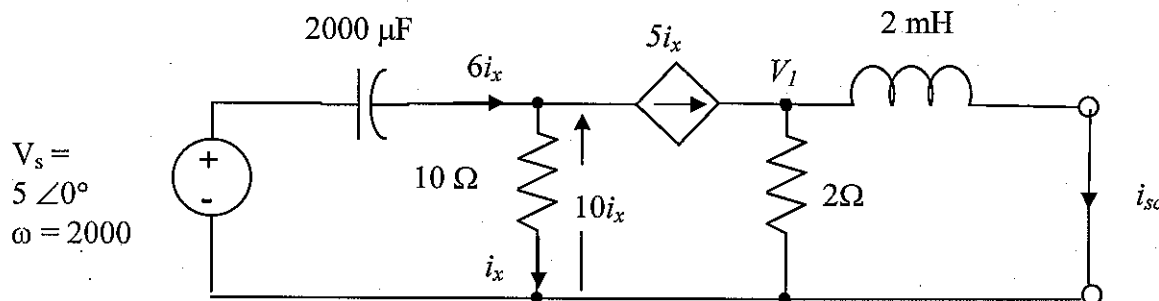

i. By current division: $i_{sc} = 5i_x \cdot [2 / (2 + j4)] = (1 - j2)i_x$

ii. From KCL: $(5 - 10i_x) \cdot j4 = 6i_x$

$$\Rightarrow i_x = j20 / (6 + j40) = 0.489 + j0.0733 = 0.494 \angle 8.53^\circ$$

$$i_{sc} = 0.636 - j0.905 = 1.11 \angle -54.9^\circ \text{ amps}$$

$$\text{So } \boxed{Z_{th} = 1.96 + j4.02 = 4.48 \angle 64.0^\circ \Omega}$$

- c) (2 pts) Determine the value of the load impedance, Z_L that will maximize the power transferred to the load.

$$\boxed{Z_L = Z_{th}^* = 1.96 - j4.02 = 4.48 \angle -64.0^\circ \Omega}$$

Problem 8 (Core: EDA-ECE3050)

Code Number: _____

Given $R_{S1} = 2\text{ k}\Omega$, $R_{D1} = 20\text{ k}\Omega$, $R_F = 18\text{ k}\Omega$, $g_{m1} = g_{m2} = 0.005\text{ S}$, $r_{ds1} = r_{ds2} = \infty$. Values for R_1 , R_2 , V^+ , and V^- are not needed to work the problem. Assume that the capacitors are short circuits for an ac signal.

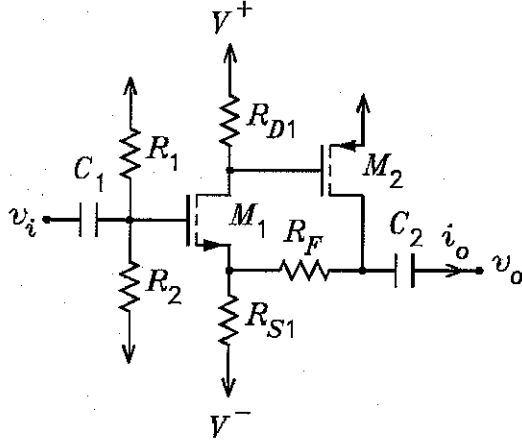

(a) Solve for the small-signal ac voltage gain.

Label i_{d1} into the drain of M_1 drain and out of the source of M_1 . Label i_{d2} out of the drain of M_2 .

$$v_i - v_o \frac{R_{S1}}{R_{S1} + R_F} \quad v_i - 0.1v_o$$

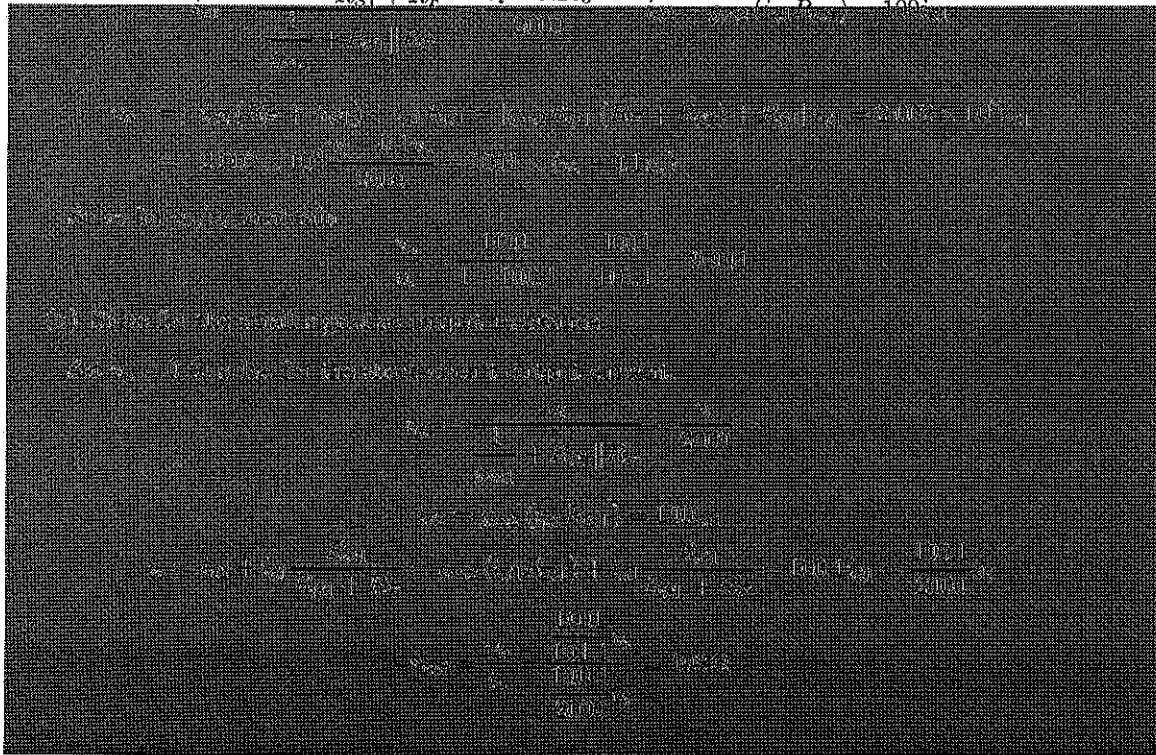

Problem 9 (Core: Power-ECE3070)

Code Number: _____

A wye connected generator provides a balanced 3 phase line-line voltage of 22,000 volts rms at 60 hertz. The load is a balanced 3 phase delta connected load, with each phase having an impedance of $10 \angle 30^\circ$ ohms.

- Calculate the power delivered to the load and the rms current rating for the generator winding
- Draw a phasor diagram with V_{AB} as reference, showing the line-neutral voltage V_{XN} for the load, as well as the current in the generator winding I_{AB} .
- Calculate the wye connected capacitance that is required to improve the load power factor to unity.

a) $I_{\text{load phase}} = \frac{22\text{KV}}{10 \angle 30^\circ} = 2.200 \text{ Arms}$

Power = $3 \times 2200 \times 22.000 \times \cos 30^\circ$
 $\boxed{= 125 \text{ MW}}$

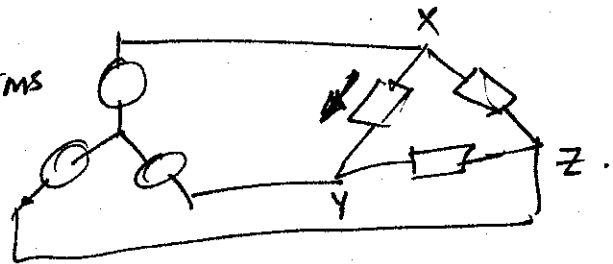

$I_{\text{rms gen}} = \sqrt{3} \times 2200 \text{ A} = \boxed{3.810 \text{ Arms}}$

b)

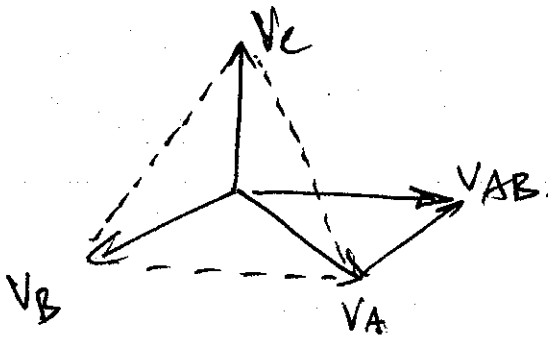

① V_{XN} is aligned with V_{AN}

②

$\boxed{\text{diagram}}$

c) $P = 125 \text{ MW} = (VA) \cdot \cos 30^\circ$

$VA = 144.3 \text{ MVAR}$

$Q = 144.3 \text{ MVAR} \times \sin 30^\circ = \boxed{72.1 \text{ MVAR}}$

each cap = $\frac{72.1}{3} = 24 \text{ MVAR} @ \frac{22.000}{\sqrt{3}} = 12.700 \text{ V}$

$I_c = 1.889 \text{ A}$

$Z_c = 6.7 \Omega = \frac{1}{\omega C}$

$\boxed{C = 395 \mu\text{F}}$

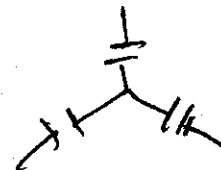

Problem 10 (Core: Power-ECE3070)**Code Number:** _____

- a) The magnetic field intensity, H , from Ampere's Law is given by,

$$H = \frac{Ni}{l} = \frac{(50)(2.0)}{0.25} = 400 \text{ At/m}$$

From the graph given in the problem, this corresponds to a flux density of 0.5 T.

The magnetic flux is then,

$$\Phi = BA = (0.5)(.002) = 0.001 \text{ Wb}$$

- b) The inductance of the coil is given by,

$$L = \frac{N\Phi}{i} = \frac{(50)(0.001)}{2.0} = 25 \text{ mH}$$

Problem 11 (Core: Microsystems-ECE3040) Code Number: _____

- i. First, this is a case for minority carrier injection. The majority carrier concentration remains constant. We can find that $n(x) = 1e16 \text{ cm}^{-3}$. (2 points)

Second, the minority carrier distribution can be derived with the minority carrier

diffusion equation: $\frac{\partial \Delta p_n}{\partial t} = D_p \frac{\partial^2 \Delta p_n}{\partial x^2} - \frac{\Delta p_n}{\tau_p} + G_L$. Per assumptions made in the

question, it can be reduced to $D_p \frac{\partial^2 \Delta p_n}{\partial x^2} - \frac{\Delta p_n}{\tau_p} = 0$ with boundary conditions: $\Delta p(0)$

$= 1e11$ and $\Delta p(\infty) = 0$.

The solution to the total minority carrier concentration is

$p(x) = p_{no} + \Delta p(x) = 10^4 + 10^{11} \exp(-x/L_p)$ (cm^{-3}), where $L_p = 20 \mu\text{m}$. (4 points)

- ii. Use the Einstein relationship to find the diffusion coefficient for holes:

$$D_p = \frac{kT}{q} \mu_p = 0.0259 * 450 = 11.66 \text{ cm}^2 / \text{s}$$

The minority carrier diffusion current density is determined by

$$\begin{aligned} J_p(x)|_{x=L_p} &= -qD_p \frac{\partial \Delta p_n}{\partial x} = q \frac{D_p}{L_p} \Delta p(0) \exp(-L_p / L_p) \\ &= 1.6 \times 10^{-19} \times \frac{11.66}{20 \times 10^{-4}} \times 10^{11} \times e^{-1} && (4 \text{ points}) \\ &= 3.4 \times 10^{-5} \text{ A/cm}^2 \end{aligned}$$

Problem 12 (Core: Microsystems-ECE3080) Code Number: _____

Consider an electron moving in the conduction band of a hypothetical semiconductor whose band structure can be approximated by:

$$E(k) = E_0 \{ 1 - \exp(-2a^2 k^2) \}$$

where a is the lattice constant of the crystal and E_0 is a constant. You may assume that the effective mass approximation holds.

Calculate the electron effective mass at the Gamma-Point (center of the Brillouin zone).

we know that $m^* = \frac{\hbar^2}{\frac{\partial^2 E}{\partial k^2}}$

$$E = E_0 (1 - e^{-2a^2 k^2})$$

$$\frac{\partial E}{\partial k} = -E_0 e^{-2a^2 k^2} (-4a^2 k)$$

$$\frac{\partial E}{\partial k} = 4a^2 E_0 k \cdot e^{-2a^2 k^2}$$

$$\frac{\partial^2 E}{\partial k^2} = 4a^2 E_0 \left[k \cdot -4a^2 k e^{-2a^2 k^2} + e^{-2a^2 k^2} \right]$$

$$\left. \frac{\partial^2 E}{\partial k^2} \right|_{\Gamma = k=0} = 4a^2 E_0 [0] + 4a^2 E_0 e^0$$

$$= 4a^2 E_0$$

$$\therefore m^* = \frac{\hbar^2}{4a^2 E_0}$$

Problem 13 (Core: DSP-ECE2025)

Code Number: _____

Consider the following system for continuous-time and discrete-time processing of a signal:

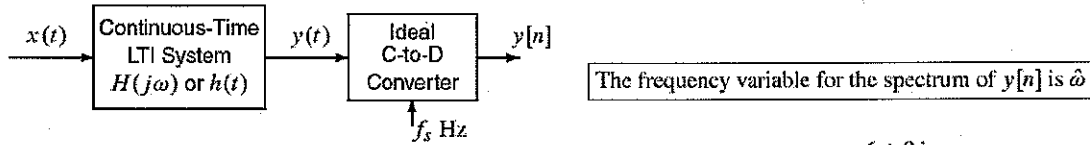

- (a) Suppose that the continuous-time system has a *known* frequency response given by $H(j\omega) = \frac{6 + 8j\omega}{3 + 2j\omega}$. Determine the impulse response for the continuous-time system.

$$H(j\omega) = \frac{6 + 8j\omega}{3 + 2j\omega} = 4 - \frac{6}{3 + 2j\omega} = 4 - \frac{3}{1.5 + j\omega}$$

$$\Rightarrow \text{Take the inverse Fourier transform } h(t) = 4\delta(t) - 3e^{-1.5t}u(t)$$

- (b) In this part assume that the frequency response $H(j\omega)$ is *unknown*. One method of measuring $H(j\omega)$ at N frequencies would be to use an input signal $x(t)$ that is the sum of N sinusoids, then sample the output $y(t)$ to obtain $y[n]$, and then use the spectrum of $y[n]$ to figure out values of $H(j\omega)$. Suppose that the input is

$$x(t) = 5\cos(2\pi(8)t + 1) + \cos(2\pi(7)t + 2) + 4\cos(2\pi(4)t) + 3\cos(2\pi(3)t + 3)$$

and the sampling rate of the ideal C-to-D converter is $f_s = 10$ samples/sec. If the spectrum of the discrete-time signal $y[n]$ is the line spectrum shown below, then some values of $H(j\omega)$ have been measured correctly.

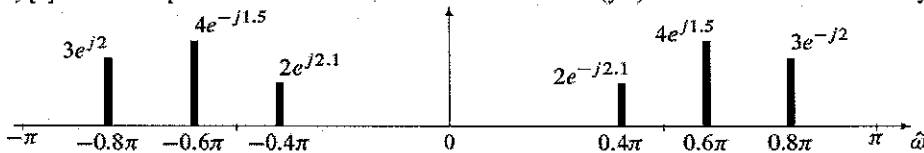

Fill in the table below with the *valid* frequencies (ω) and the corresponding *correct values* of $H(j\omega)$ (magnitude and phase in polar form). Only positive frequencies need to be tabulated. **EXPLAIN your answer.**

ω	$H(j\omega)$
$2\pi(3)$	Impossible
$2\pi(4)$	$1.5e^{-j2}$
$2\pi(7)$	Impossible
$2\pi(8)$	$0.8e^{-j1.1}$

The input $x(t)$ has 4 sinusoids at the frequencies, $\omega/2\pi = \{8, 7, 4, 3\}$. The output of the C-T system is a different sum of the 4 sinusoids at the same frequencies. After the C-to-D converter, the frequencies are mapped using the relationship $\hat{\omega} = \omega/f_s$ and some are aliased by subtracting 2π :

$$\begin{aligned} \omega = 2\pi(\pm 8) &\rightarrow \hat{\omega} = \pm 16\pi/10 = \pm 1.6\pi \rightarrow \mp 0.4\pi & \omega = 2\pi(\pm 4) &\rightarrow \hat{\omega} = \pm 0.8\pi \\ \omega = 2\pi(\pm 7) &\rightarrow \hat{\omega} = \pm 14\pi/10 = \pm 1.4\pi \rightarrow \mp 0.6\pi & \omega = 2\pi(\pm 3) &\rightarrow \hat{\omega} = \pm 0.6\pi \end{aligned}$$

Since we can write the input $x(t)$ and the output $y(t)$ in terms of complex exponentials, we can track each frequency component through the system and through the C-to-D converter:

$$x(t) = 2.5e^{j1}e^{j2\pi(8)t} + 0.5e^{j2}e^{j2\pi(7)t} + 2e^{j2\pi(4)t} + 1.5e^{j3}e^{j2\pi(3)t} + \text{Neg. Freq. terms (conjugate)}$$

$$y(t) = H(j16\pi)2.5e^{j1}e^{j2\pi(8)t} + H(j14\pi)0.5e^{j2}e^{j2\pi(7)t} + H(j8\pi)2e^{j2\pi(4)t} + H(j6\pi)1.5e^{j3}e^{j2\pi(3)t} + \text{Neg. Freq. term}$$

The term at $\omega = 2\pi(4)$ corresponds to the spectrum line at $\hat{\omega} = 0.8\pi$, and the term at $\omega = 2\pi(8)$ corresponds to the spectrum line at $\hat{\omega} = -0.4\pi$, so we have

$$2H(j2\pi(4)) = 3e^{-j2} \Rightarrow H(j2\pi(4)) = 1.5e^{-j2} \quad \text{and} \quad H(j2\pi(8))2.5e^{j1} = 2e^{-j2.1} \Rightarrow H(j2\pi(8)) = 0.8e^{-j1.1}$$

The terms at $\omega = \pm 2\pi(3)$ and $\omega = \mp 2\pi(7)$ land on top of one another in the $\hat{\omega}$ domain, so they add together, and there is no way to determine either $H(j2\pi(7))$, or $H(j2\pi(3))$ from this one term in the $\hat{\omega}$ domain.

Problem 14 (Core: DSP-ECE3075)

Code Number: _____

X and Y are statistically independent random variables with the following pdf's:

$$f_X(x) = \frac{1}{2}\delta(x) + \frac{1}{2}\delta(x-2) \text{ where } \delta(x) \text{ is the Dirac delta function.}$$

$$f_Y(y) = \lambda e^{-\lambda y} \text{ for } y > 0;$$

$$= 0 \text{ otherwise.}$$

(a) Find the probability that $X > Y$.

$X > Y$ iff $X = 2$ and $Y < 2$

$$\text{Pr}(X > Y) = \frac{1}{2} \cdot \int_0^2 \lambda e^{-\lambda y} dy = \frac{1}{2}(1 - e^{-2\lambda})$$

(b) Let $R = 2X - 5Y$. Find $E(R)$ and σ_R^2 .

$$\bar{X} = 1$$

$$\bar{Y} = \frac{1}{\lambda}$$

$$\sigma_X^2 = 1$$

$$\sigma_Y^2 = \frac{1}{\lambda^2}$$

$$\bar{R} = 2(1) - 5\left(\frac{1}{\lambda}\right) = 2 - \frac{5}{\lambda}$$

$$\sigma_R^2 = 4(1) + 25\left(\frac{1}{\lambda^2}\right)$$

$$= 4 + \frac{25}{\lambda^2}$$

Problem 14 (cont.) (Core: DSP-ECE3075)

Code Number: _____

Let X_1, X_2, \dots, X_M be jointly Gaussian random variables, each with mean 2 and variance 4.

(c) Find the pdf for $W = 3X_1$.

$$W \sim \mathcal{N}(6, 36) = \mathcal{N}(2 \cdot 3, 3^2 \cdot 4)$$

(d) Find the pdf for $V = X_1 + X_2$, where $E(X_1 X_2) = 6$.

$$\begin{aligned} V &\sim \mathcal{N}(4, 4 + 2\rho \cdot 4 + 4) \\ &= \mathcal{N}(4, 12) \end{aligned}$$

$$\begin{aligned} \rho &= \frac{6 - 4}{4} = \frac{1}{2} \\ &= \frac{\overline{X_1 X_2} - \bar{X}_1 \bar{X}_2}{\sqrt{\sigma_{X_1}^2} \sqrt{\sigma_{X_2}^2}} \end{aligned}$$

(e) Find σ_Z^2 where $Z = \frac{1}{M} \sum_{i=1}^M X_i$ and the X_i 's are uncorrelated.

$$\sigma_Z^2 = \frac{1}{M^2} \cdot M \cdot \sigma_{X_i}^2 = \frac{4}{M}$$

Solution:

In order to ensure that the sinusoidal disturbance has no effect on the output it is necessary that the transfer function from disturbance to output has a notch at the corresponding frequency. To ensure this we need an (internal model) controller which replicates the dynamics of the disturbance, this must be of the form

$$C(s) = \frac{???}{(???) (s^2 + \omega_0^2)}$$

where $\omega_0 = 120\pi$. The requirement of being second order limit our options to

$$C(s) = \frac{as^2 + bs + c}{(s^2 + \omega_0^2)}$$

It is not difficult to see by root-locus considerations that a nontrivial numerator is needed in order for the closed loop system to be stable. A simple solution which makes computations easy for for the purposes of an exam, is to use one of the controller zeros to cancel one of the left-half-plane poles of $G(s)$ and place the other in such a location so that together with the remaining pole of $G(s)$ it forms a lead element, i.e., it is to the right of the remaining pole. With such a choice the root locus (for positive gain) will lie completely in the left half plane. In absence of any other specification any selection of K will be good (on paper). Thus we may select

$$C(s) = \frac{(s+100)(s+0.5)}{s^2 + \omega_0^2}$$

Problem 16 (Core: S&C-ECE3085)**Code Number:** _____

Consider the second-order SISO system with the following transfer function:

$$G(s) = \frac{s+1}{s^2+4s+4}$$

The poles and zeros have specific properties regarding the system response.

- (a) An input, based on the zero, can produce no output depending on the initial condition. Find the initial condition such that $y(t) = 0$ given $u(t) = e^{-t}1(t)$, where $1(t)$ is the unit step function.
- (b) Find the initial condition such that the free response of the system is $y(t) = 5e^{-2t}$ for $t \geq 0$; e.g. the output is induced by the pole. The free response of the system is the output of the system for a given initial condition given no input, $u(t) = 0$.

The solution can be done using the exponential solution, state space, or Laplace domain mathematics. The Laplace domain solution will be done in more detail than necessary.

Solution (Laplace + Time). Use the initial value theorem applied to

$$\ddot{y} + 4\dot{y} + 4y = \dot{u} + u$$

in order to obtain:

$$\begin{aligned} s^2Y - sy(0) - \dot{y}(0) + 4Y - 4y(0) + 4Y &= sU - u(0) + U \\ (s^2 + 4s + 4)Y - (s+4)y(0) - \dot{y}(0) &= (s+1)U - u(0), \end{aligned}$$

where all evaluations at the limit 0 are from below.

For problem (a), we have that $U = 1/(s+1)$ and $u(0) = 0$. Furthermore, the output vanishes so $Y = 0$,

$$-(s+4)y(0) - \dot{y}(0) = 1.$$

Solving for the initial output and its derivative gives $y(0) = 0$ and $\dot{y}(0) = 1$.

Moving to problem (b), we have $u(t) = 0$, $U(s) = 0$, $y(t) = 5e^{-2t}$, and $Y(s) = 5/(s+2)$, leading to

$$\begin{aligned} (s^2 + 4s + 4)\frac{5}{s+2} - (s+4)y(0) - \dot{y}(0) &= 0 \\ 5(s+2) - (s+4)y(0) - \dot{y}(0) &= 0 \\ (5 - y(0))s + (10 - 4y(0) - \dot{y}(0)) &= 0. \end{aligned}$$

The solution to the initial output and its derivative is $y(0) = 5$ and $\dot{y}(0) = -10$.

This characterizes the outputs and is enough to resolve the rest.

In particular, one can use the output to determine what the initial condition of internal states of the system needs to be. The relation between the two is $Y(s) = (s+1)X(s)$ meaning that $y(t) = x(t) + \dot{x}(t)$. Using the characteristic polynomial and the fact that the inputs vanish at $t = 0$ we also get the following:

$$\begin{aligned} y(0) &= x(0) + \dot{x}(0) \\ \dot{y}(0) &= -4x(0) - 3\dot{x}(0). \end{aligned}$$

As a matrix,

$$\begin{Bmatrix} y(0) \\ \dot{y}(0) \end{Bmatrix} = \begin{bmatrix} 1 & 1 \\ -4 & -3 \end{bmatrix} \begin{Bmatrix} x(0) \\ \dot{x}(0) \end{Bmatrix}$$

whose solution for $x(0)$ and $\dot{x}(0)$ is

$$\begin{Bmatrix} x(0) \\ \dot{x}(0) \end{Bmatrix} = \begin{bmatrix} -3 & -1 \\ 4 & 1 \end{bmatrix} \begin{Bmatrix} y(0) \\ \dot{y}(0) \end{Bmatrix}$$

Plugging in what we know from the initial output conditions, we get as the solution for problem (a), $x(0) = 1$ and $\dot{x}(0) = -1$. The corresponding solution for problem (b) is $x(0) = -5$ and $\dot{x}(0) = 10$.

Consider the second-order SISO system with the following transfer function:

$$G(s) = \frac{s+1}{s^2+4s+4}$$

The poles and zeros have specific properties regarding the system response.

- An input, based on the zero, can produce no output depending on the initial condition. Find the initial condition such that $y(t) = 0$ given $u(t) = e^{-t}1(t)$, where $1(t)$ is the unit step function.
- Find the initial condition such that the free response of the system is $y(t) = 5e^{-2t}$ for $t \geq 0$; e.g. the output is induced by the pole. The free response of the system is the output of the system for a given initial condition given no input, $u(t) = 0$.

The solution can be done using the exponential solution, state space, or Laplace domain mathematics. The Laplace domain solution will be done in more detail than necessary.

Solution (Laplace + Time). Use the initial value theorem applied to

$$\ddot{y} + 4\dot{y} + 4y = \dot{u} + u$$

in order to obtain:

$$\begin{aligned} s^2Y - sy(0) - \dot{y}(0) + 4Y - 4y(0) + 4Y &= sU - u(0) + U \\ (s^2 + 4s + 4)Y - (s+4)y(0) - \dot{y}(0) &= (s+1)U - u(0), \end{aligned}$$

where all evaluations at the limit 0 are from below.

For problem (a), we have that $U = 1/(s+1)$ and $u(0) = 0$. Furthermore, the output vanishes so $Y = 0$,

$$-(s+4)y(0) - \dot{y}(0) = 1.$$

Solving for the initial output and its derivative gives $y(0) = 0$ and $\dot{y}(0) = 1$.

Moving to problem (b), we have $u(t) = 0$, $U(s) = 0$, $y(t) = 5e^{-2t}$, and $Y(s) = 5/(s+2)$, leading to

$$\begin{aligned} (s^2 + 4s + 4)\frac{5}{s+2} - (s+4)y(0) - \dot{y}(0) &= 0 \\ 5(s+2) - (s+4)y(0) - \dot{y}(0) &= 0 \\ (5 - y(0))s + (10 - 4y(0) - \dot{y}(0)) &= 0. \end{aligned}$$

The solution to the initial output and its derivative is $y(0) = 5$ and $\dot{y}(0) = -10$.

This characterizes the outputs and is enough to resolve the rest.

In particular, one can use the output to determine what the initial condition of internal states of the system needs to be. The relation between the two is $Y(s) = (s+1)X(s)$ meaning that $y(t) = x(t) + \dot{x}(t)$. Using the characteristic polynomial and the fact that the inputs vanish at $t = 0$ we also get the following:

$$\begin{aligned} y(0) &= x(0) + \dot{x}(0) \\ \dot{y}(0) &= -4x(0) - 3\dot{x}(0). \end{aligned}$$

As a matrix,

$$\begin{Bmatrix} y(0) \\ \dot{y}(0) \end{Bmatrix} = \begin{bmatrix} 1 & 1 \\ -4 & -3 \end{bmatrix} \begin{Bmatrix} x(0) \\ \dot{x}(0) \end{Bmatrix}$$

whose solution for $x(0)$ and $\dot{x}(0)$ is

$$\begin{Bmatrix} x(0) \\ \dot{x}(0) \end{Bmatrix} = \begin{bmatrix} -3 & -1 \\ 4 & 1 \end{bmatrix} \begin{Bmatrix} y(0) \\ \dot{y}(0) \end{Bmatrix}$$

Plugging in what we know from the initial output conditions, we get as the solution for problem (a), $x(0) = 1$ and $\dot{x}(0) = -1$. The corresponding solution for problem (b) is $x(0) = -5$ and $\dot{x}(0) = 10$.

Problem 17 (Specialized: Comp Science-CS3210) Code Number: _____

Using C-like or Java-like pseudo-code, give an algorithm that will arbitrate access to critical sections between *two* processes. The algorithm must be executed by the two processes themselves, using only user-level operations, i.e. no OS support can be used, and it cannot make use of any hardware synchronization primitives, i.e. it must be a software-only solution. Hardware synchronization primitives that cannot be used include all atomic read-modify-write instructions, e.g. test-and-set and compare-and-swap, and no instruction combinations such as load-locked and store-conditional. You must argue informally why your solution satisfies the three requirements for critical section access, namely mutual exclusion, progress, and bounded waiting.

Let the two processes be process 0 and process 1. The wait() routine is executed when a process i wants to enter its critical section and the exit() routine is executed after process i exits its critical section, where $i = 0$ or 1.

```
wait() {
    waiting[i] = true;
    j = (i+1) mod 2;
    turn = j;           // give the other process a turn using shared variable turn
    while (waiting[j] && turn == j); // wait for i's turn
    return;
}

exit() {
    waiting[i] = false;
}
```

Mutual exclusion is guaranteed because a process i only enters its critical section if j is not waiting or the shared turn variable indicates that it is i 's turn. If process j is not waiting, then mutual exclusion is preserved and j will not be able to enter its critical section until i finishes and indicates it is no longer waiting. The only way the shared turn variable can be set to i when process i is in its while loop is if j set turn to i *after* i set turn to j . In this case, process j will be blocked from entering its critical section since i is waiting and turn is equal to i . Thus, mutual exclusion is achieved.

Progress is achieved because a process that wants to enter its critical section will do so immediately if the other process is not waiting. If the other process is waiting, one of the two will enter immediately and will give the turn to the other when its critical section is completed. Bounded waiting follows from the same reasoning.

Problem 18 (Specialized: Software Sys- ECE3035) Code Number: _____

Part A Show how the struct definition below maps to memory. Assume it is allocated starting at address 5000. For each variable, draw a box showing its size and position in memory. Label the box with the variable name. Label each element of an array (e.g., Name[0]).

	5000	Name[0]	Name[1]	Name[2]	Name[3]
struct Dog {	5004	Name[4]	Name[5]	Name[6]	Age
char	5008	Weight			
unsigned char	5012	MyBreed			
double	5016	Next			
struct Breed *MyBreed;	5020				
struct Dog *Next;	5024				
}					

Part B Suppose the following variables are allocated beginning at address 6000. Complete the table below, listing the value of the expression following this definition.

```
int A[10] = {0, 1, 2, 3, 4, 5, 6, 7, 8, 9};
int *P = A;
```

A	6000	A + 5	6020	&(A[9])	6036	P - 1	5996
A[3]	3	P[3+4]	7	A == P	1	P++	6004

Explain what happens if **A** is incremented (e.g. **A++**).

The compiler will issue an error stating A is a constant, not a variable, therefore it cannot be incremented.

Part C The following MiniC code declares a three-dimensional array `A` by `int A[3][4][5]`. Determine the address of `A`.

Assume the array starts in memory at address 1000. Assume the array is stored in row-major order.

Determine the address of the element `A[2][2][2]`.

Element Size: 4 bytes 12 20 bytes 12 5 bytes

Problem 19 (Specialized: Telecom-ECE3076) Code Number: _____

Question 1 – IP Datagrams

What field in the IP header changes when a datagram is forwarded by a simple router? _____ **Time to Live (TTL)**

What other field always changes when a IP datagram if forwarded by a NAT router? _____ **Local IP Address** _____

What other field may or may not change, depending on the NAT implementation? _____ **Local TCP or UDP port** _____

When is the ID number used? _____ **When an IP segment is fragmented** _____

Question 2 – Ethernet and IEEE 802.11 (WiFi) Which things are the same or different

Which things are in both the two protocols, or WiFi only, or Ethernet only? (answer: "Both", "WiFi", or "Ethernet").

6-byte MAC addresses, first few bytes assigned to the vendor, unique. _____ **Both** _____

Resends frames that are not acknowledged _____ **WiFi** _____

Carrier Sense Multiple Access (CSMA) _____ **Both** _____

Collision Avoidance _____ **WiFi** _____

Collision Detection _____ **Ethernet** _____

Question 3 – Cell Phone Modulation and Multiple Access (answers: __DMA - write out the first word, before DMA)

What multiple access technique was used with the first cell phones (AMPS): _____ **Frequency** _____

What multiple access technique was used with the first digital cell phones _____ **Time** _____

What multiple access technique was used with the later digital cell phones _____ **Code** _____

Which technique is always used, alone or with one of the other two? _____ **Frequency** _____

Problem 20 (Specialized: Optics-ECE4500) Code Number: _____

Transmission through and Reflection from a Thin Slab

For maximum transmission, the slab should have an optical thickness that is a multiple of a half wavelength. The minimum thickness occurs when it is one half wavelength.

$$d(\text{maximum transmission}) = \frac{\lambda}{2n}$$

For maximum reflection, the slab should have an optical thickness that is an odd multiple of a quarter wavelength. The minimum thickness occurs when it is one quarter wavelength.

$$d(\text{maximum reflection}) = \frac{\lambda}{4n}$$

For the case of silicon ($n = 3.48$) at a wavelength of $\lambda = 1.55 \mu\text{m}$.

$$d(\text{maximum transmission}) = \frac{\lambda}{2n} = 222.7 \text{ nm}$$

$$d(\text{maximum reflection}) = \frac{\lambda}{4n} = 111.4 \text{ nm}$$

Problem 21 (Specialized: Optics-ECE4501) Code Number: _____

Optical Fiber

For a conventional optical fiber telecommunications fiber operating near 1550nm:

- Qualitatively sketch the ω - β diagram for a single mode fiber showing the effects of waveguide dispersion.
- Identify the limiting slopes, the zero dispersion point and the group velocity of the sketch in a)
- Write the group velocity in terms of $\beta(\omega)$
- List in order of increasing effect, the primary dispersion mechanisms in optical fiber.
- Explain the underlying mechanism of each in part d)
- Describe the wavelength dependence of each dispersion mechanism.

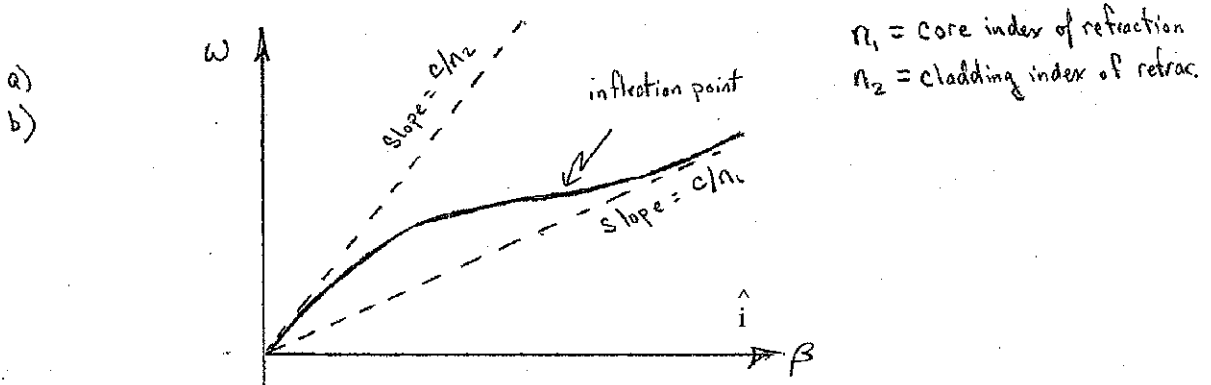

c)

$$\text{group velocity } v_g = \frac{d\omega}{d\beta} \left[\frac{1}{\text{m}} \right] \quad \because \text{slope} = \text{group velocity}$$

$$\text{group velocity dispersion} = \frac{d^2\beta}{d\omega^2} \Rightarrow \text{zero dispersion point is the inflection point}$$

- d) Dispersion mechanisms
- waveguide : for a single transverse mode the confinement and group index varies with λ .
 - material : index of refraction is wavelength dependent
 - modal : in fibers that support multiple transverse modes; in general each mode exhibits a different group index.

Problem 22 (Specialized: Microsystems-ECE4752) Code Number: _____

ECE4752 Problem

Design the complete process flow used to fabricate an electron beam evaporated aluminum conductor pattern onto a silicon wafer. The process flow should use the lift-off technique and positive photoresist. The process flow should include completely labeled cross sections of each step, and a one sentence explanation of each cross section, and Mask cross section at the appropriate photolithography step.

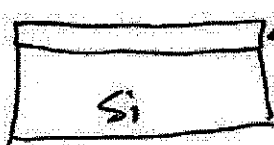

← Photoresist

- Spin coat PR

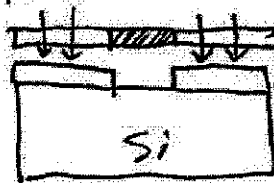

← Mask
← Exposed PR

- Expose + Develop PR

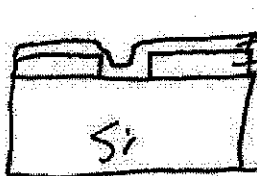

← Sputter Al
← Exposed PR

- Sputter Al film

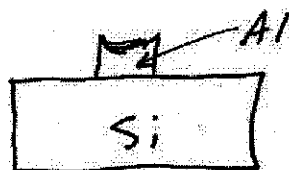

- Remove PR
- Lift of Al

Problem 23 (Specialized: Bio Eng-ECE4784) Code Number: _____

$$V = -\frac{8.31 \cdot 290}{z \cdot 96485} \ln\left(\frac{C_{in}}{C_{out}}\right) = \frac{-0.025}{z} \ln\left(\frac{C_{in}}{C_{out}}\right)$$

(a) $V_K = \frac{-0.025}{1} \ln\left(\frac{400}{28}\right) = -66.4 \text{ mV}$

$$V_{Na} = \frac{-0.025}{1} \ln\left(\frac{50}{450}\right) = 54.9 \text{ mV}$$

$$V_{Cl} = \frac{-0.025}{-1} \ln\left(\frac{40}{550}\right) = -65.5 \text{ mV}$$

(b)
$$V_{rest} = \frac{g_K \cdot V_K + g_{Na} \cdot V_{Na} + g_{Cl} \cdot V_{Cl}}{g_K + g_{Na} + g_{Cl}} = \frac{0.415 \cdot (-66.4) + 0.010 \cdot (54.9) + 0.582 \cdot (-65.5)}{0.415 + 0.010 + 0.582} \text{ mV} = -64.7 \text{ mV}$$

$$J_K = g_K(V_{rest} - V_K) = 0.415(-0.06 + 0.0665) = 2.66 \frac{\mu\text{A}}{\text{cm}^2}, \text{ Potassium ion flows in the extracellular direction}$$

(c)
$$J_{Na} = g_{Na}(V_{rest} - V_{Na}) = 0.010(-0.06 - 0.0549) = -1.15 \frac{\mu\text{A}}{\text{cm}^2}, \text{ Sodium ion flows in the intracellular direction}$$

$$J_{Cl} = -g_{Cl}(V_{rest} - V_{Cl}) = -0.582(-0.06 + 0.0655) = -3.18 \frac{\mu\text{A}}{\text{cm}^2}, \text{ Chloride ion (negative charge) flows in the intracellular direction}$$

Problem 24 (Specialized: Bio Eng-ECE4781) Code Number: _____

What is a Skeletal Motor Unit in the context of Neurology?

(3 points)

One motor neuron plus all of the muscle cells that it innervates.

“Turn Arouds” are used by Neurologists to diagnose abnormal EMG signals. What is a Turn Around?

(2 points)

When a Neurologist is looking at a needle (epidermal) EMG signal, he/she attempts to isolate a portion of the signal coming from a single Skeletal Motor Unit. The up/down oscillations, i.e. the Turn Arouds, of the signal indicates the synchronization of the separate contractions of the muscle cells which are innervated by the same neuron.

Draw a box diagram representing each electronic component and power sources required to amplify, filter and digitize a human EMG signal.

(3 points)

The stages required are differential preamp, filter, amp, isolator, sample and hold, and A-to-D converter. The components before the isolator must be battery powered and isolated from line ground.

How would you use a computer to analyze the human EMG signal to determine if there is an abnormal number of Turn Arouds? Why is this computation difficult?

(2 points)

Computer programs are available that attempt to isolate Skeletal Motor Units and then plot the numbers of Turn Arouds found during a specified period of time.

Neuromuscular disorders are indicated when a lot of 4+ Turn Arouds are identified.

Unfortunately, it is very difficult to tell the difference between sequentially firing Skeletal Motor Units with 2 Turn Arouds and one Skeletal Motor Unit with 4 Turn Arouds.

Problem 25 (Specialized: Bio Eng-ECE4782) Code Number: _____

A. Describe how "Brain Mappers" are used in Operating Rooms to monitor anesthesia. (4 points)

EEG data is collected from discrete locations on the patient's scalp for a specified period of time. The patient's head is depicted on a monitor with colored areas that indicate the predominate frequency of EEG measured at each location. Additional EEG signals are approximated by interpolating between adjacent locations where the EEG is measured. Anesthesiologists are looking for regions that have predominantly low frequencies, i.e. Delta. A sketch could be used to show a typical display.

B. What statistics are calculated? (3 points)

EEG data is collected from discrete locations on the scalp for a specified period of time. The Power Spectral Density is calculated for each EEG signal, which is defined as the Fourier Transform of the Autocorrelation Function. FFT algorithms are commonly used. The spectral plots are analyzed to determine which characteristic band contains the most energy, i.e. Delta (DC-4Hz), Theta (4-8Hz), Alpha (8-14Hz), and Beta (14-30Hz).

C. A Brain Mapper could be constructed without using a computer. Using a box diagram, describe how to use op amps and other analog components to approximate the desired statistics.

(3 points)

Each EEG signal is first input into a narrow bandpass filter. The filtered signal is then squared. The squared signal is then integrated for a specified period of time. The output is then plotted as an approximation of the power level at the center frequency of the bandpass filter. The center frequency of the bandpass filter is then changed to estimate the next spectral value. A block diagram could be used.